

PRO-FIT® WHIRLPOOL & BATHTUB

4260 TFS 59 3/4" x 42" x 21 1/4"

Model number: 6124/6624 LH, 6125/6625 RH

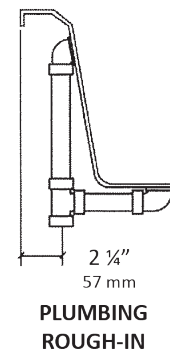
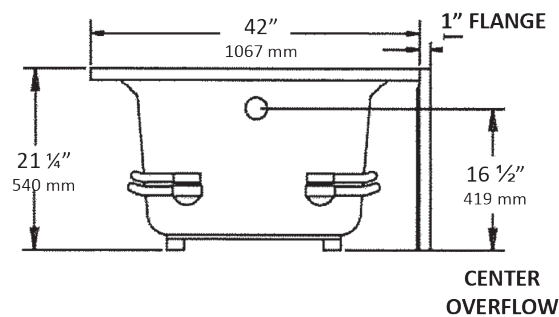
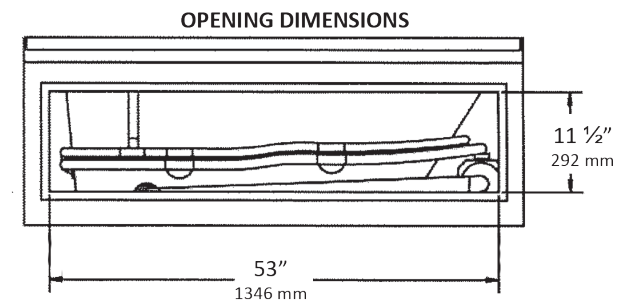
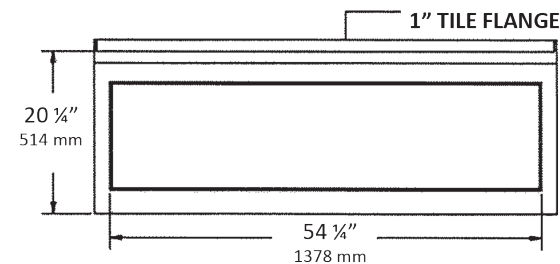
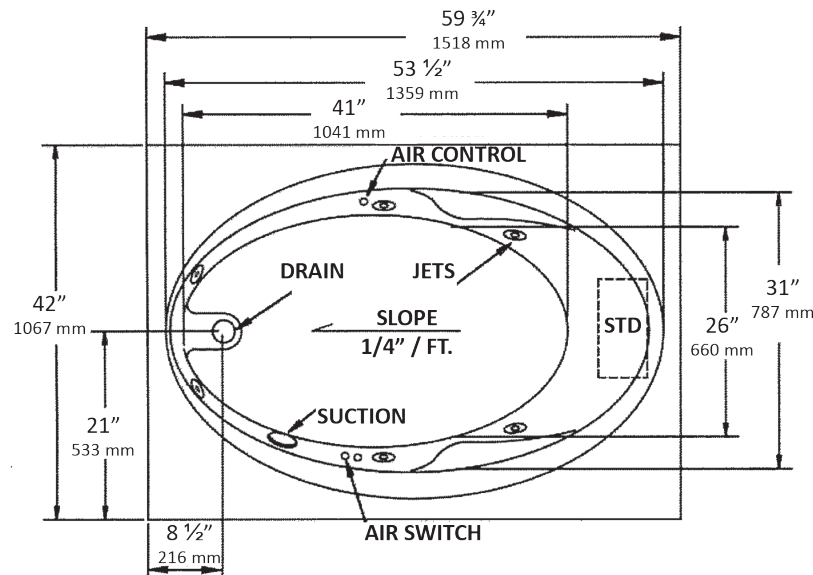

NOTES:

1. Pump location shown for clarity.
2. Required pump/motor access is 20" W x 15" H.
3. Measurements may vary 1/4" (+/-).
4. Apron is integral with optional removable access panel for access to pump/motor.
5. Due to integral tile flange, a nailing flange is not available on this unit.
6. Specify LH or RH drain when ordering.

SPECIFICATIONS:

| | | | |
|--------------------------|---|------------------|---|
| Dimensions: | 59 3/4" x 42" x 21 1/4" | Number of jets: | 6 |
| Material: | Acrylic, fiberglass reinforced | Weight: | 100 lbs. (41 kg) |
| Pump Motor: | 120 V, 60 HZ, 6.0 Amp, Single Speed, Premounted | Water Capacity: | 55 gals max., 42 gals min. 160 liters/103 liters) |
| Electrical Requirements: | 120 V, 15 Amp, GFCI Protected | Floor Loading: | 47 lbs./sq.ft. (229 kg/m ²) |
| On/Off Control: | Air Switch | Shipping Weight: | 146 lbs. |