

# 138-160RH ALTO®



Elongated Front, Vitreous China, Two-Piece Toilet

## FEATURES

- 3-bolt SmartFasten™ tank-to-bowl connection
- 1.6 gpf / 6.0 lpf low water consumption
- Elongated front bowl
- 2" flush tower
- Fluidmaster® anti-siphon pilot fill valve
- 10" rough-in
- Model 40RH chrome-plated, plastic trip lever
- 2" glazed trapway
- The Mansfield® limited lifetime warranty
- Available in White



**MODEL 138-160RH**

Toilet seat not included



## COMPONENTS

MODEL #	DESCRIPTION	CODES/STANDARDS
138-160RH	Elongated front, two-piece toilet.	
138	Elongated front, toilet bowl only. Less toilet seat. Specify color.	
160RH	Tank and cover only, with right hand, front-mount, chrome-plated, plastic trip lever. Fluidmaster® anti-siphon pilot fill valve. Less supply.	
TANK TRIM & REPLACEMENT PARTS		
40RH	Trip lever - chrome-plated, plastic trip lever, right hand	
211-1112	Flush tower	
400A	Fluidmaster® anti-siphon pilot fill valve	
630-0030	Replacement flush valve seal	
160-LID	Tank lid	

# 138-160RH ALTO®



Elongated Front, Vitreous China, Two-Piece Toilet

## SPECIFICATIONS

MODEL #	DESCRIPTION	CODES/STANDARDS
138-160RH	Elongated front (1.6 gpf / 6.0 lpf) two-piece toilet	

MATERIAL	Vitreous China
WATER PRESSURE RANGE	20 to 80 PSI
FLUSH SYSTEM	2" Flush Tower
WATER USAGE	1.6 gpf / 6.0 lpf
WATER SURFACE AREA	9" X 10"
ROUGH-IN	10"
MaP RATING	800 grams

TRAP DIAMETER	2"
TRAP SEAL	2-1/2"
SHIPPING WEIGHT	Model 138 - 49 lbs. (22.2 kg) Model 160RH - 34 lbs. (15.4 kg)
WARRANTY	Vitreous China - Limited Lifetime Tank Trim - Limited One Year

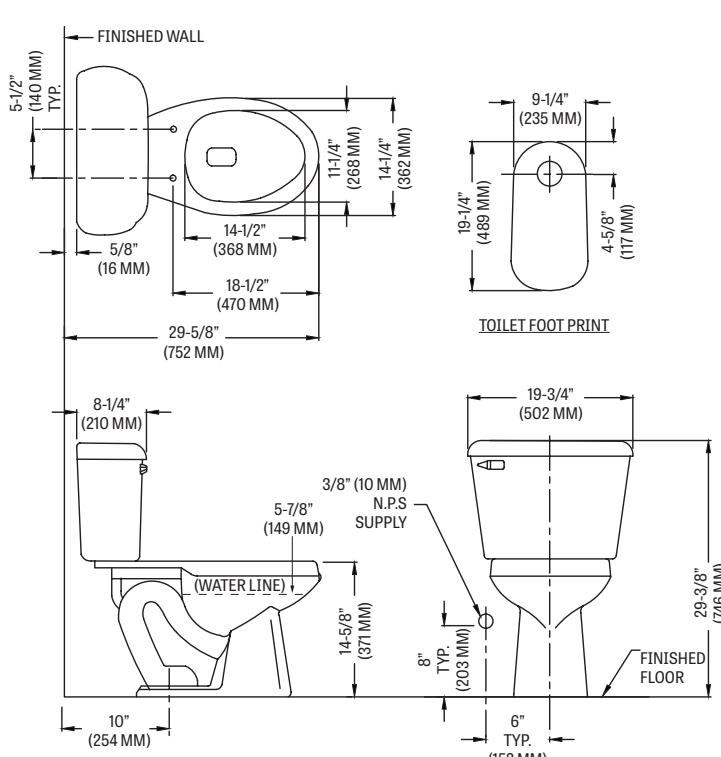
TANK OPTIONS	TECHNICAL INFORMATION																						
<table border="1"> <tbody> <tr> <td>160</td> <td><b>Standard 1.6 gpf configuration:</b> 2" flush tower, Fluidmaster® anti-siphon pilot fill valve, left hand, chrome trip lever.</td> </tr> <tr> <td>160RH</td> <td>Variation of model 160, with right hand trip lever.</td> </tr> <tr> <td>165</td> <td>Variation of model 160, with cover lock.</td> </tr> <tr> <td>170</td> <td>Variation of model 160, with tank liner.</td> </tr> <tr> <td>172</td> <td>Variation of model 160, with 2" flapper flush valve and chrome trip lever.</td> </tr> <tr> <td>173</td> <td>Variation of model 160, with 2" flapper flush valve and color-match trip lever.</td> </tr> <tr> <td>173RH</td> <td>Variation of model 173, with right hand trip lever.</td> </tr> <tr> <td>174</td> <td>Variation of model 173, with tank liner.</td> </tr> <tr> <td>175</td> <td>Variation of model 160, with cover lock and tank liner.</td> </tr> <tr> <td>180</td> <td>Variation of model 160, with color-match trip lever.</td> </tr> <tr> <td>190</td> <td>Variation of model 160, with color-match trip lever and tank liner.</td> </tr> </tbody> </table>	160	<b>Standard 1.6 gpf configuration:</b> 2" flush tower, Fluidmaster® anti-siphon pilot fill valve, left hand, chrome trip lever.	160RH	Variation of model 160, with right hand trip lever.	165	Variation of model 160, with cover lock.	170	Variation of model 160, with tank liner.	172	Variation of model 160, with 2" flapper flush valve and chrome trip lever.	173	Variation of model 160, with 2" flapper flush valve and color-match trip lever.	173RH	Variation of model 173, with right hand trip lever.	174	Variation of model 173, with tank liner.	175	Variation of model 160, with cover lock and tank liner.	180	Variation of model 160, with color-match trip lever.	190	Variation of model 160, with color-match trip lever and tank liner.	<p><b>Note:</b> these dimensions are nominal and subject to change without notice.</p> 
160	<b>Standard 1.6 gpf configuration:</b> 2" flush tower, Fluidmaster® anti-siphon pilot fill valve, left hand, chrome trip lever.																						
160RH	Variation of model 160, with right hand trip lever.																						
165	Variation of model 160, with cover lock.																						
170	Variation of model 160, with tank liner.																						
172	Variation of model 160, with 2" flapper flush valve and chrome trip lever.																						
173	Variation of model 160, with 2" flapper flush valve and color-match trip lever.																						
173RH	Variation of model 173, with right hand trip lever.																						
174	Variation of model 173, with tank liner.																						
175	Variation of model 160, with cover lock and tank liner.																						
180	Variation of model 160, with color-match trip lever.																						
190	Variation of model 160, with color-match trip lever and tank liner.																						

Fixture performance and specifications meet or exceed ASME A112.19.2/CSA B45.1 standards, and other state and local codes.