

GIG25

GIGABYTE GAMING CHAIR

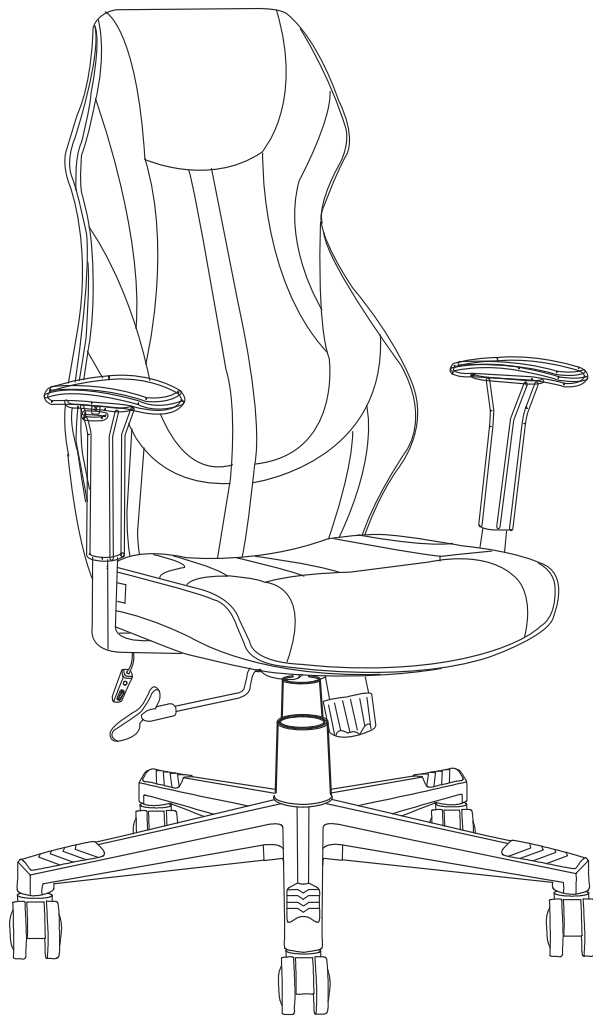

Assembly Instructions - Important:

Carefully unpack and identify each component before attempting to assemble. Refer to parts list. Please take care when assembling the unit and always set the parts on a clean, soft surface. If you require any assistance with assembly, parts or information on other products, please visit our website: www.officestar.net or call or write us.

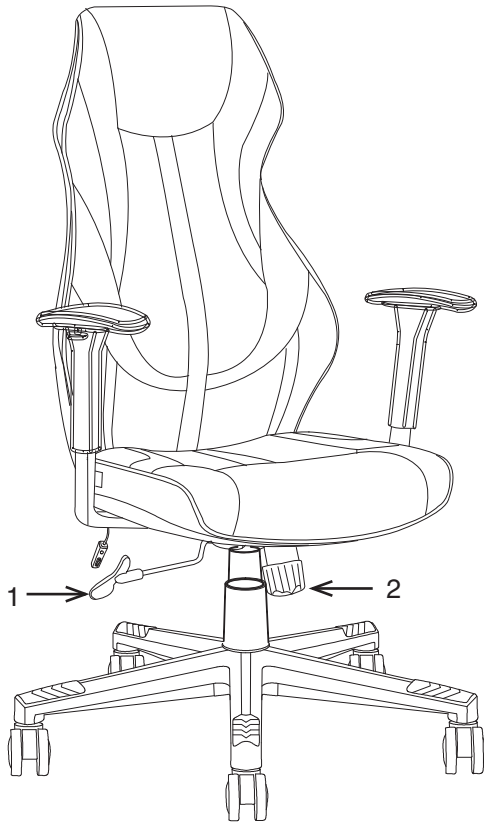

FEATURES

- **PNEUMATIC SEAT HEIGHT ADJUSTMENT**

To raise seat remove pressure from seat and pull lever (1) up.

To lower seat height sit on chair and pull lever (1) up.

NOTE: It is normal for chair to slightly lower under body weight.

- **LOCKING TILT ADJUSTMENT**

For individual comfort, this chair has been equipped with an adjustment that will allow the user to change the tension of the tilting feature. Turn knob (2) clockwise to increase tension and counter-clockwise to decrease or ease the tension. To lock return chair to the upright position and push lever (1) in. To unlock pull lever (1) out.

NOTE: Be careful not to loosen back tilt adjustment knob completely.

- **LED LIGHTING & ADJUSTMENT**

Use LED controller to change the LED light colors.

1. Do not use this product unless all screws and bolts are securely tightened.
2. Check that all screws and bolts are tight every three months or as needed.
3. Dispose of packing material properly. Do not use plastic cover as head covering. It may cause suffocation.
4. Do not use this product as a stepladder.
5. Use this product for its intended purpose only.
6. **FOR INDOOR RESIDENTIAL USE ONLY.**

OSP HOME FURNISHINGS OFFICE CHAIRS LIMITED WARRANTY

- 2 Years on all non-moving metal parts.
- 1 Year on component parts including Control mechanisms, pneumatic cylinders, wood, plastic parts, base and casters.
- 1 Year on upholstery fabric and foam against wear and deterioration.
- We cannot warrant leather against routine scratching and scuffing, as all leather is subject to minor blemishes in normal use.

All warranties are limited to the original purchaser for normal Residential usage by persons weighing 250 lbs. or less.

This warranty will not cover labor, freight or damage from misuse, abuse, negligence, alteration, accident, vandalism, rusting, acts of nature or any other event beyond the control of Office Star Products. The warranty does not cover cosmetic damage that may result from normal use. Liability for incidental or consequential damages is excluded. The user assumes all risk of injury resulting from use of this product. This warranty gives you specific legal rights, and you may also have other rights which vary from state to state.

Our quality standards are among the highest in the industry. Sometimes, no matter how hard we try, there are times when parts are damaged or missing. Our Parts Department will do everything possible to promptly remedy the problem. Contact us via e-mail parts@officestar.net, by Fax 1-909-930-5629, or toll free parts number 1-800-950-7262, Monday through Friday 8:00 a.m. - 5:00 p.m. Pacific Time.

To make a warranty claim, contact Parts Department. Provide model number, proof of purchase, description of the problem and obtain return authorization. At its option OSP Home Furnishings will:

(a) Supply compatible components of current manufacture.

(b) Repair the customer's component. The customer must prepay freight on any components returned to the factory. Return freight on components still in warranty will be paid by OSP Home Furnishings.

PARTS

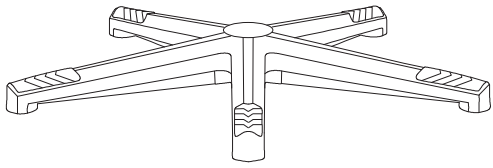

(A) Base (1 PC)



(B) Caster (5 PCS)



(C) Pneumatic Cylinder (1 PC)



(D) Bellows (1 PC)

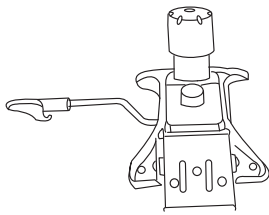

(E) Seat Plate (1 PC)

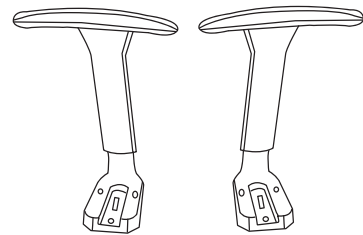

(F) Left and Right Arm (2 PCS)

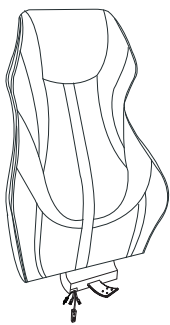

(G) Backrest (1 PC)





(H) Seat Cushion (1 PC)



(I) Power Adapter (1 PC)

HARDWARE LIST

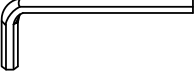
NO	DRAWING	DESCRIPTION	QUANTITY
1		Bolt	3 PCS
2		Bolt	8 PCS
3		Bolt	2 PCS
4		Allen Wrench	1 PC

STEP 1

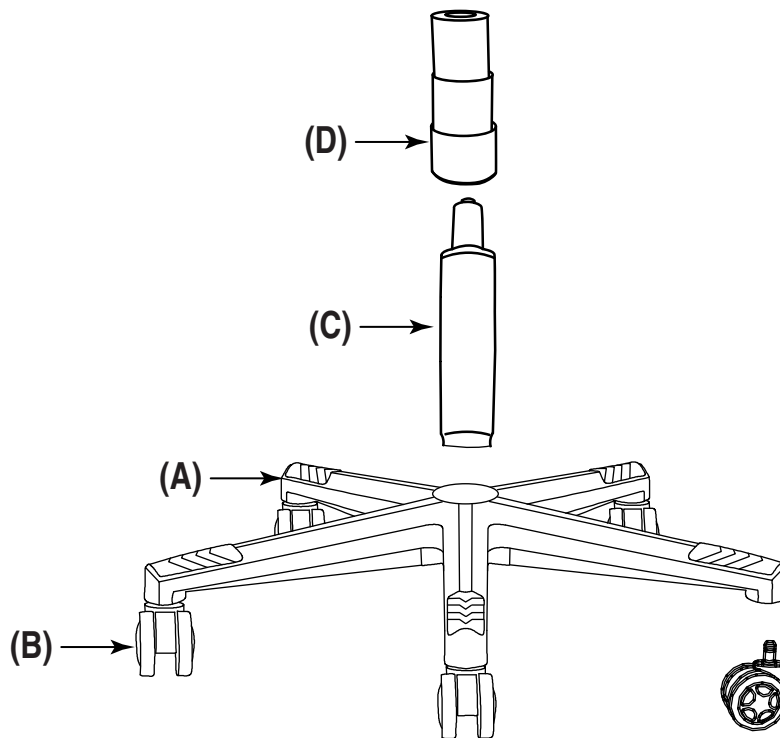

INSERT FIVE CASTERS (B) INTO BASE (A), PUSH HARD UNTIL YOU FEEL OR HEAR THE CASTER (B) SNAP INTO PLACE.
INSERT PNEUMATIC CYLINDER (C) INTO BASE (A) AND SLIP BELLOWS (D) OVER PNEUMATIC CYLINDER (C).

STEP 2

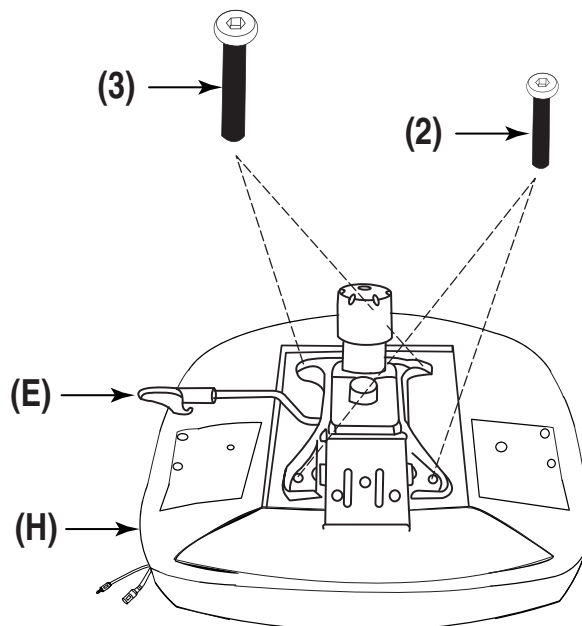

ATTACH SEAT PLATE (E) TO SEAT CUSHION (H) WITH THE ARROW TOWARDS THE FRONT OF THE CHAIR USING TWO BOLTS (3) FOR FRONT HOLES AND TWO BOLTS (2) FOR REAR HOLES. FULLY TIGHTEN BOLTS.

STEP 3

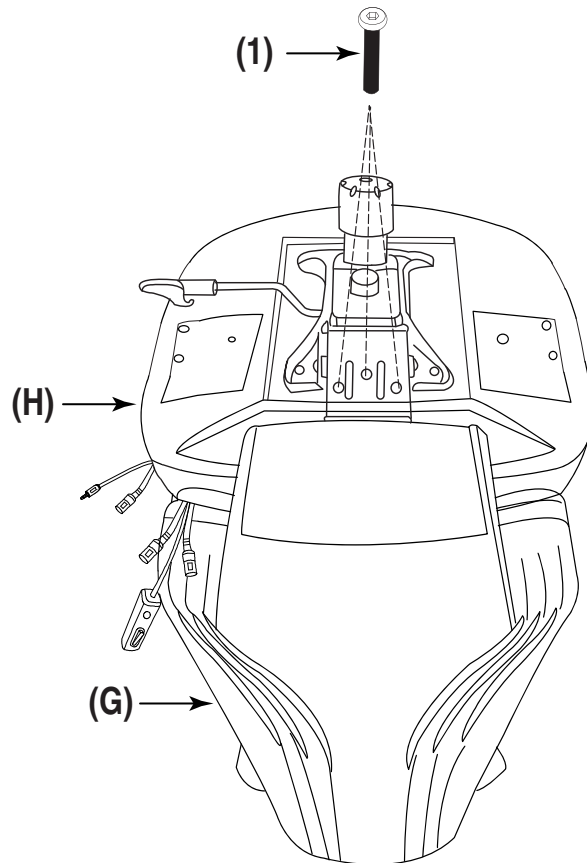

ATTACH BACKREST (G) TO REAR OF SEAT CUSHION (H) USING THREE BOLTS (1). FULLY TIGHTEN BOLTS (1).

STEP 4

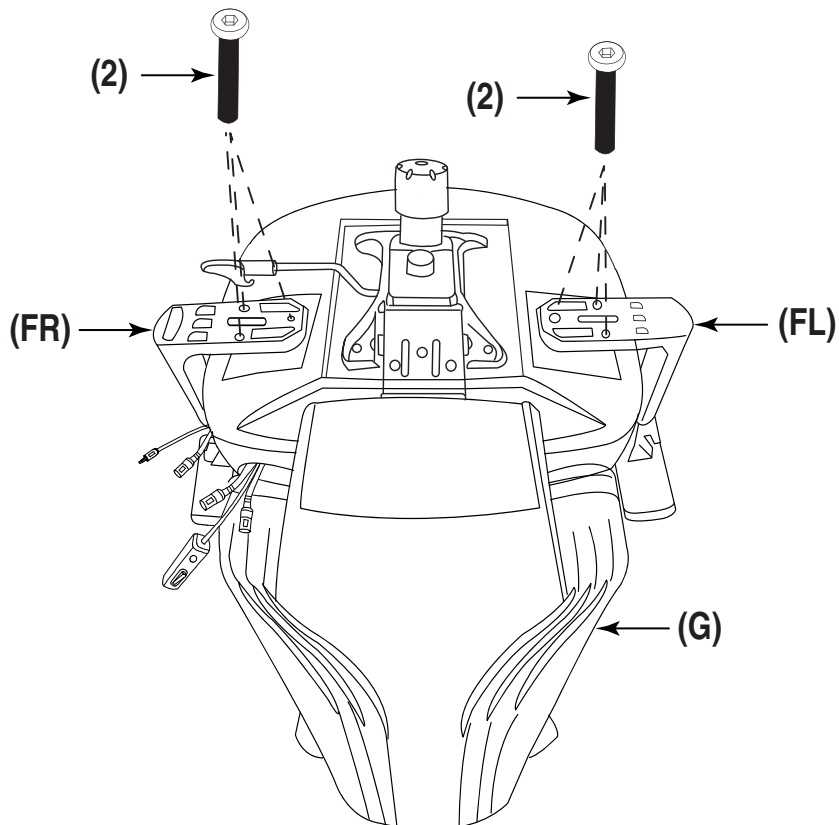

ATTACH ARMS (FL & FR) TO SEAT CUSHION (H) USING THREE BOLTS (2) FOR EACH ARM (F), FULLY TIGHTEN BOLTS (2).

STEP 5

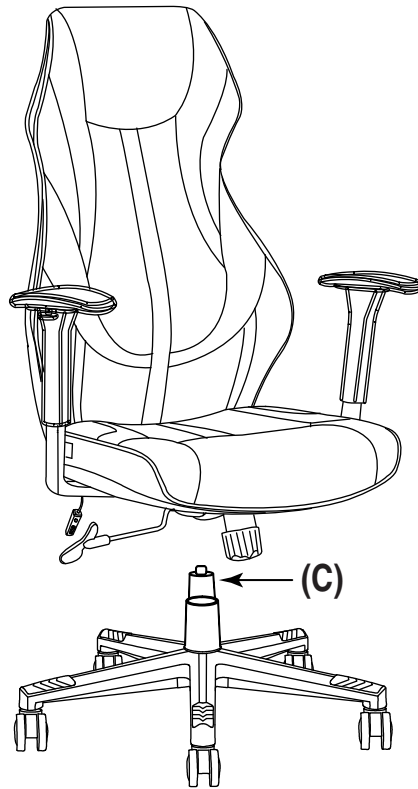

PLACE THE ASSEMBLED SEAT ON TOP OF PNEUMATIC CYLINDER (C) AND APPLY DOWNWARD PRESSURE.

STEP 6

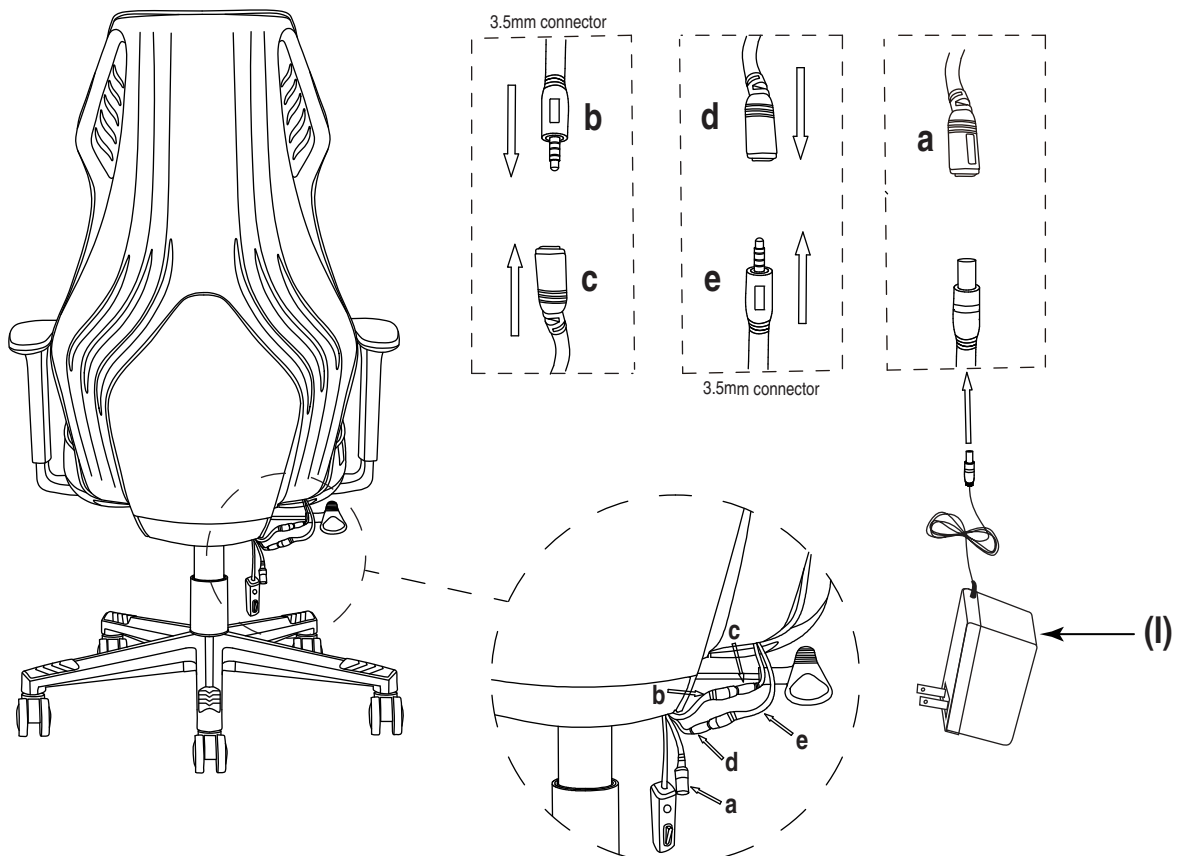

CONNECT CORDS B TO C AND D TO E. CONNECT POWER ADAPTER (I) TO CORD A.