

# 5346 AVA™ DROP-IN 3570



## Swirl-Way® Air Massage Bath

The air massage bath uses a blower to create huge, soothing bubbles all throughout your bathtub. The bubbles are created when heated air is forced through the air injectors and into your water. Let the bubbles caress your body as they rise to the top.

### FEATURES

- 70" x 35" x 26-1/2"
- Installation: Drop-In
- High gloss, easy-to-clean acrylic with fiberglass reinforcement
- Oval model with center drain
- Pre-leveled legs for easy installation
- Ergonomic bathing well for ultimate relaxation
- Spacious area to mount the faucet on the deck
- Designed for two person comfort
- Ten-year warranty for acrylic shell; five-year labor warranty for all factory installed components
- Available in White, Biscuit, Bone, Black, British Khaki and Ice Gray



### FEATURES & OPTIONS



MODEL NUMBER	FEATURES, OPTIONS & COMPONENTS	SWIRL-WAY® AIR MASSAGE BATH
--	Multi-function Electronic Keypad	Included
--	Invisible air injectors with check valves	Included
VSC100	Variable Speed Blower	Included
SWA500	Chromatherapy Mood Light System	Included
--	Automatic Purge and Dry Cycle	Included
LDFK-	Linear Overflow Drain Chrome - 1335 Everbrass - 1336 Brushed Nickel - 1337 Oil Rubbed Bronze - 1338	Included - Finish must be specified on order
PREM-	Premium Acrylic Colors BLK - Black BKHK - British Khaki IGRY - Ice Gray *Trim Upgrade (No charge) must be selected with any Premium Acrylic Color.	Optional
SWA100	Pillows (Two)	Included

# 5346 AVA™ DROP-IN 3570



Swirl-way® Air Massage Bath

## SPECIFICATIONS

MODEL #	DESCRIPTION	CODES/STANDARDS
5346	70' x 35' x 26-1/2' Air Massage Bath	 

MATERIAL	Acrylic, Fiberglass reinforced	WARRANTY	Limited Ten Year
CONSTRUCTION	Self-contained, pre-plumbed air massage bath system mounted on a pre-leveled base.	SHIPPING WEIGHT	160 lbs.
NUMBER OF JETS	32 air jets	WATER CAPACITY	44 gal. (min), 57 gal. (max)
FLOOR LOADING WEIGHT	47 lbs. / sq. ft.	DIMENSIONS	70' x 35' x 26-1/2'
<b>PRODUCT DETAILS</b>			
BLOWER MOTOR	Variable Speed - 1.0 HP, 120 V, 9 AMP	OPERATION:	20 minute time cycle
ON/OFF CONTROL	Multi-function electronic keypad	PURGE AND DRY CYCLE:	Automatic, 20 minutes after operation, the blower will reactivate to begin drying process.
ELECTRICAL REQUIREMENTS	One 120V, 20 AMP GFCI dedicated circuit		

## TECHNICAL INFORMATION

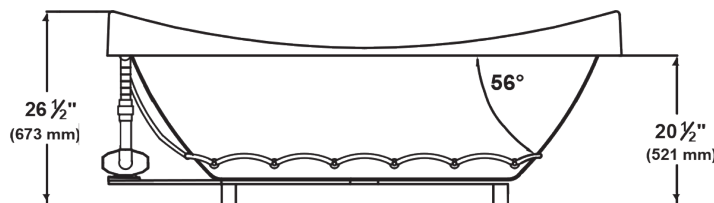
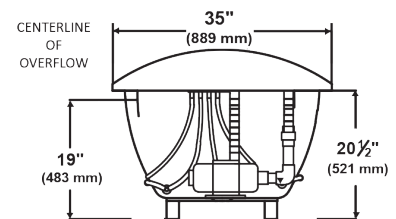
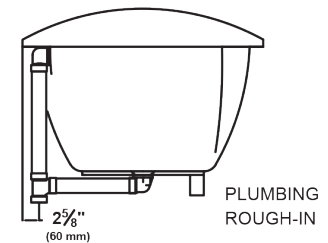
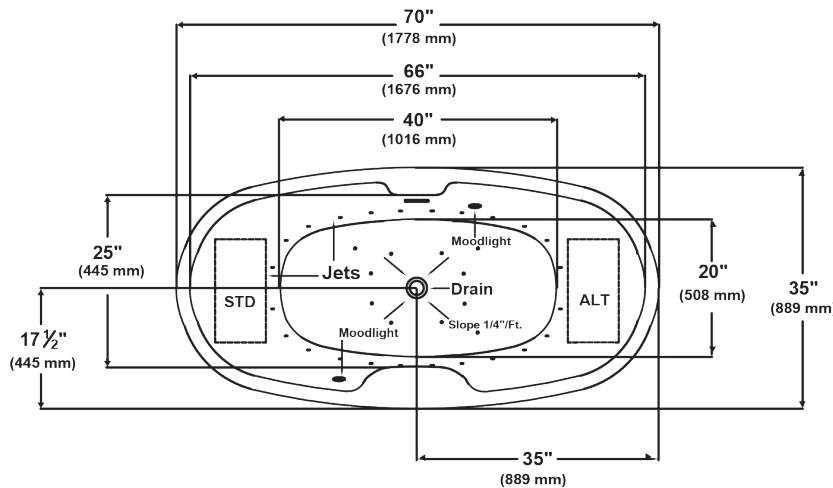

### NOTES:

- 1) Blower locations shown for clarity. Specify when ordering. STD - Standard or ALT - Alternate.
- 2) Required blower motor access is 20" W x 15" High
- 3) Measurements may vary 1/4" (+/-)
- 4) Nail Flange is not available for this unit.
- 5) Removable apron is not available for this unit.
- 6) These dimensions are nominal and subject to change without notice.