

ITEM NO. 3488680 / MODEL NO. 5135CTK

PRO-FIT®**MANSFIELD®**

Elongated Front, Vitreous China, Two-Piece Toilet, Complete Toilet Kit

FEATURES

- Complete toilet kit (CTK)
- 1.28 gpf / 4.8 lpf high efficiency water consumption
- Universal style matches any decor
- Elongated front bowl
- 3-2" hybrid flapper flush valve
- Fluidmaster® pilot operated anti-siphon fill valve
- 12" rough-in
- SmartFasten™ 3-bolt tank-to-bowl connection
- Model 31 color-match, plastic trip lever
- 2" glazed trapway
- The Mansfield® limited lifetime warranty on china, One-year limited warranty on tank trim
- Available in White

**MODEL 5135CTK**

Toilet seat included

Complete Toilet Kit



CTK

ELONGATED

COMPONENTS

MODEL #	DESCRIPTION	CODES/STANDARDS
5135CTK	Elongated front complete two-piece toilet kit. Includes: toilet seat, tank and bowl, floor bolts, wax ring, caps and multi-lingual installation instructions. Water supply not included.	
135	Elongated front toilet bowl only.	
3173	Tank and lid only. With left hand, front-mount, color-match plastic trip lever.	
SB200	Elongated, plastic toilet seat	
TANK TRIM & REPLACEMENT PARTS		
31	Trip Lever - color-match plastic trip lever, left hand	
400A	Fluidmaster® anti-siphon pilot fill valve	
228	3-2" Hybrid flapper flush valve	
2206	Anti-siphon pilot fill valve (compatible replacement)	
630-0207	3" Replacement flapper kit	
160-LID	Tank lid	

ITEM NO. 3488680 / MODEL NO. 5135CTK



PRO-FIT®

MANSFIELD®



Elongated Front, Vitreous China, Two-Piece Toilet, Complete Toilet Kit

SPECIFICATIONS

MODEL #	DESCRIPTION	CODES/STANDARDS
5135CTK	Elongated front (1.28 gpf/4.8 lpf) two-piece toilet kit	  
MATERIAL	Vitreous China	TRAP DIAMETER 2"
WATER PRESSURE RANGE	20 to 80 PSI	TRAP SEAL 2-1/2"
FLUSH SYSTEM	3-2" Hybrid flapper flush valve	SHIPPING WEIGHT Model 5135CTK - 88 lbs. (40 kg)
WATER USAGE	1.28 gpf / 4.8 lpf	WARRANTY Vitreous China - Limited Lifetime Tank Trim - Limited One-Year
WATER SURFACE AREA	9" X 10"	
ROUGH-IN	12"	
MAp RATING	800 grams	

TECHNICAL INFORMATION

Note: these dimensions are nominal and subject to change without notice.

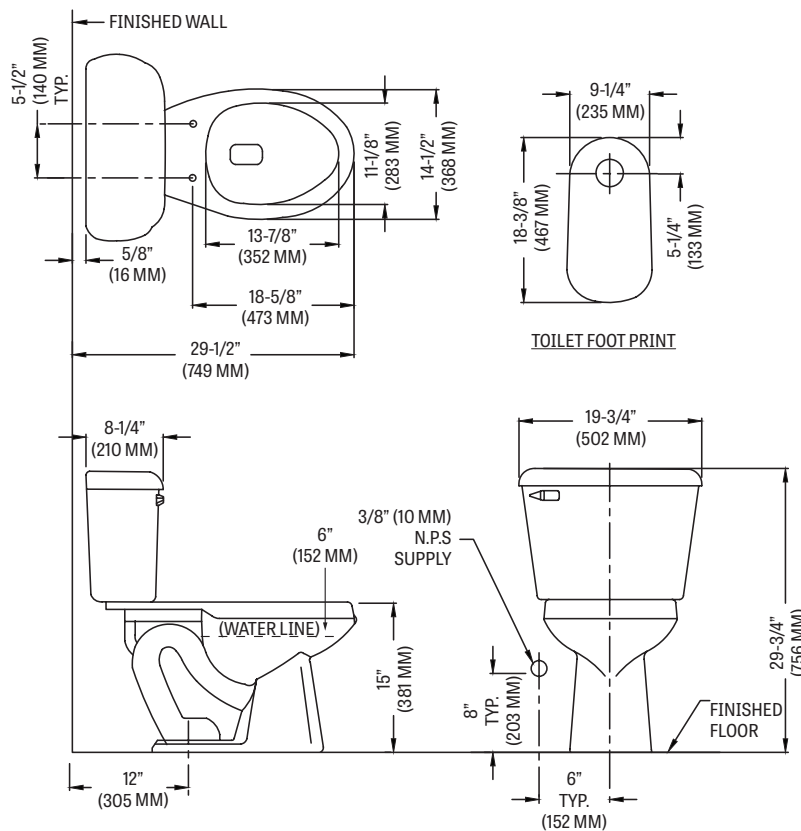

Fixture performance and specifications meet or exceed ASME A112.19.2/CSA B45.1 standards, and other state and local codes.