

PRO-FIT® WHIRLPOOL & BATHTUB

4268 OV ED 68" x 42" x 20"

Model number: 6030/6530

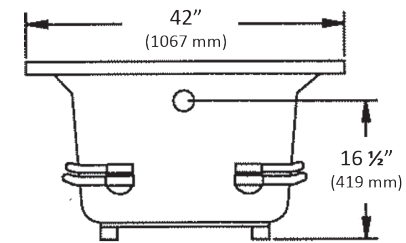
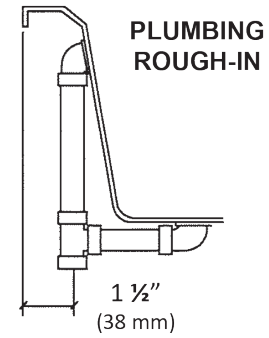
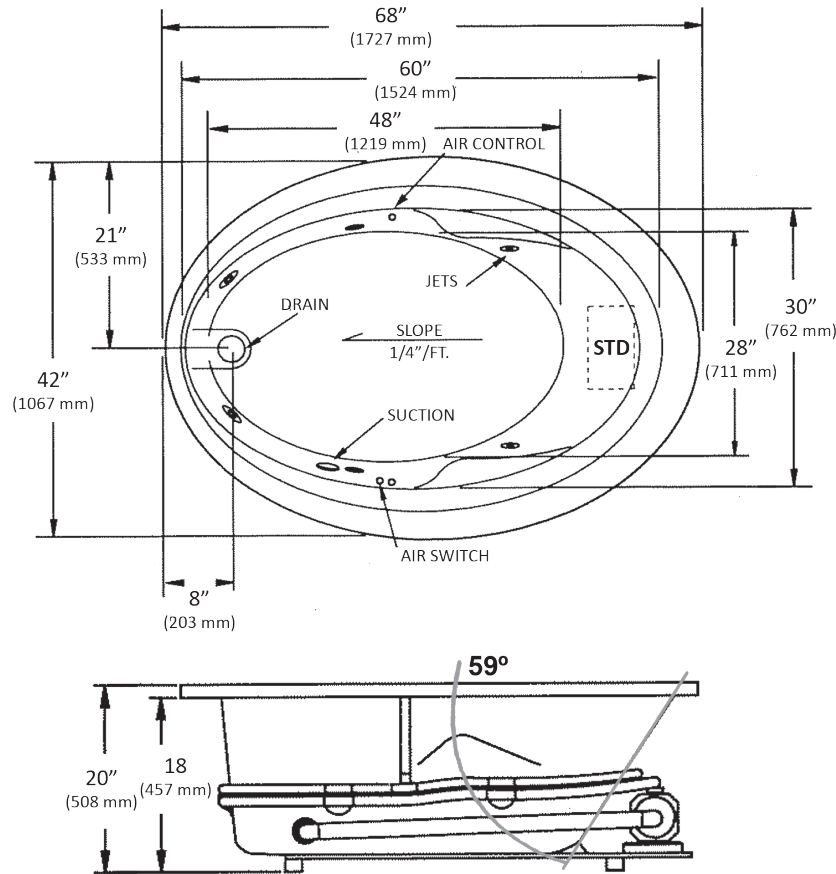

CENTER OVERFLOW

NOTES:

1. Pump location shown for clarity.
2. Required pump motor access is 20" W x 15" H.
3. Measurements may vary 1/4" (+/-).
4. Optional removable apron is not available on this unit.
5. Installer note: Due to the freeform shape of the tub shell, it is recommended that the tub be on the job site before making the final cut-out for drop-in or undermount installation.

SPECIFICATIONS:

Dimensions:	68" x 42" x 20"	Number of jets:	6
Material:	Acrylic, fiberglass reinforced	Weight:	120 lbs.
Pump Motor:	120 V, 60 HZ, 6.0 Amp, Single Speed, Premounted	Water Capacity:	74 gals max., 59 gals min.
Electrical Requirements:	120 V, 15 Amp, GFCI Protected	Floor Loading:	47 lbs./sq.ft. (229 kg/m ²)
On/Off Control:	Air Switch	Shipping Weight:	158 lbs. / 138 lbs.