

5069/5569

MANSFIELD®

**Brentwood™ 60" x 36" x 22 1/2"
Swirl-way® Whirlpool and Bathtub**

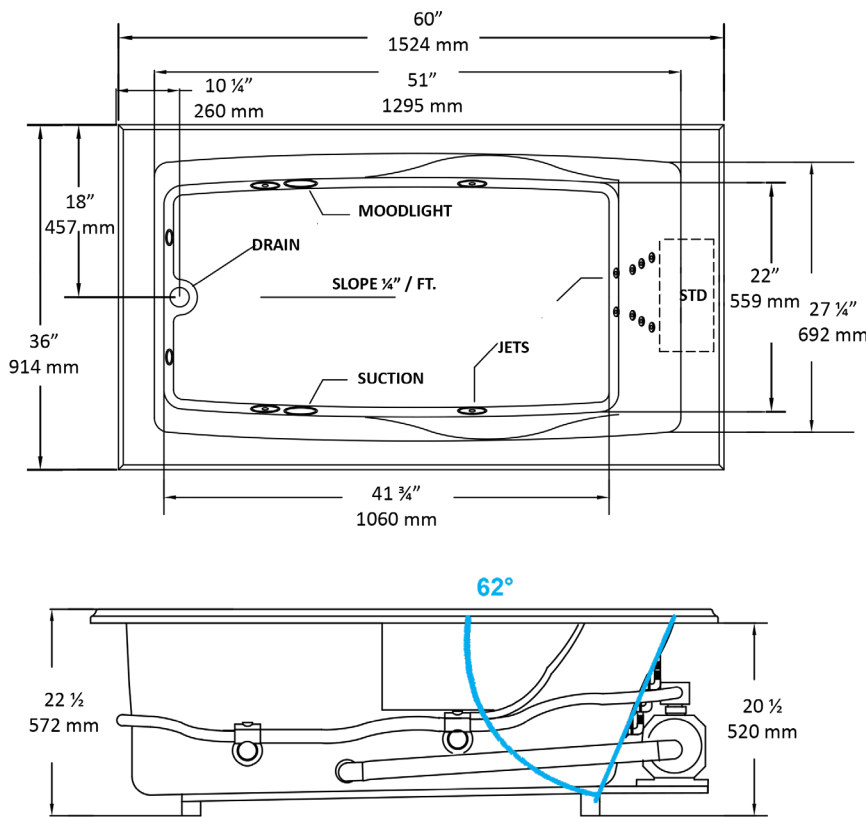

**PLUMBING
ROUGH-IN**

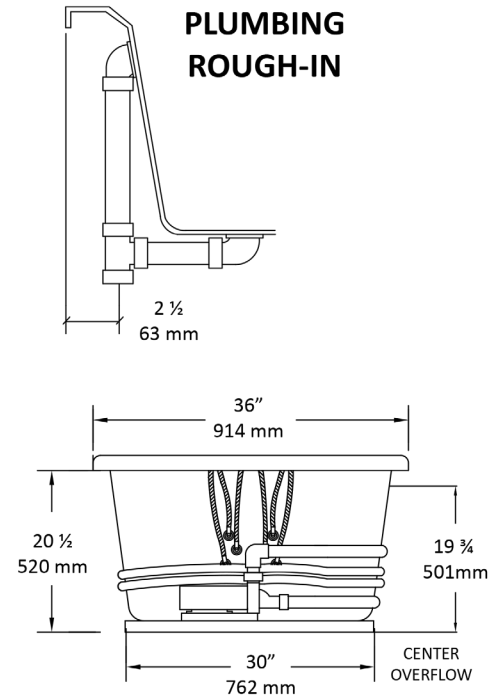

NOTES:

1. Pump location is shown for clarity.
2. Required pump motor access is 20" W x 15" H.
3. Measurements may vary 1/4" (+/-)
4. If a factory installed nailing flange is added to a unit, add 1/8" to each side flanged.
5. Removable apron is not available for this unit.
6. These dimensions are nominal and subject to change without notice.

SPECIFICATIONS

Specification	Description	Specification	Description
Material	Acrylic, fiberglass reinforced	Warranty	Limited Ten Year
Construction	Self-contained, pre-plumbed whirlpool bath system mounted on a pre-leveled base	Water Capacity	56 gal. (min) 66 gal. (max)
Number of Jets	14	Shipping Weight	Whirlpool - 160 lbs Bathtub - 150 lbs
Floor Loading Weight	47 lbs. / sq.ft.		
ESSENTIALS PACKAGE		COMFORT PACKAGE	
Pump Motor	Single speed induction pump, 9 AMP	Pump Motor	Variable speed induction pump, 9 AMP
On/Off Control	One button on/off electronic keypad	On/Off Control	Multi-function electronic keypad
Electrical Requirements	One 120V, 20 amp GFCI dedicated circuit. Optional heater: separate 120 V, 20 amp dedicated circuit.	Electrical Requirements	Two separate 120 V, 20 amp dedicated circuits

