

# 5552 LANA™ DROP-IN 3260



## Swirl-Way® Bathtub

Soak and relax in your warm-water bathtub as you sink into the deep bathing well. Allow your troubles to melt away and feel the calm of the soothing water.

### FEATURES

- 60" x 32" x 21-1/4"
- Installation: Drop-In or Alcove
- High gloss, easy-to-clean acrylic with fiberglass reinforcement
- Rectangular model with end drain
- Pre-leveled legs for easy installation
- Ergonomic bathing well for ultimate relaxation
- Spacious area to mount the faucet on the deck
- Ten-year warranty for acrylic shell
- Available in White, Biscuit, Bone, Black, British Khaki and Ice Gray

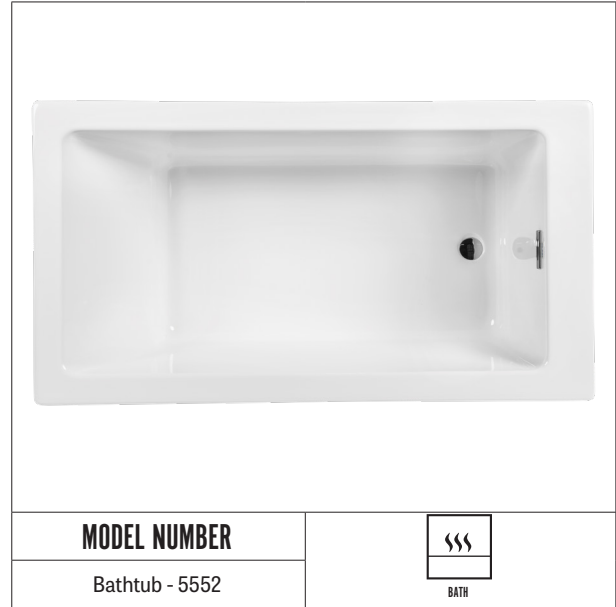

### HYDROTHERAPY SYSTEMS

MODEL NUMBER	FEATURES, OPTIONS & COMPONENTS	SWIRL-WAY® BATHTUB
CHS151	Constant Heat System	Optional
LDK-	Linear Overflow Drain Chrome - 1335 Everbrass - 1336 Brushed Nickel - 1337 Oil Rubbed Bronze - 1338	Included - Finish must be specified on order
PREM-	Premium Acrylic Colors BLK - Black BKHK - British Khaki IGRY - Ice Gray	Optional
SWPLO	Low profile 5/8" deck	Optional
SWP150L	Factory Installed Nail Flange - Left Hand Drain	Optional
SWP150R	Factory Installed Nail Flange - Right Hand Drain	Optional
SWP150S	Factory Installed Nail Flange - Special, Diagram Required	Optional
SWAPO0	Nailing Flange Kit (Field Installed)	Optional
SWA100	Pillow (One)	Included

# 5552 LANA™ DROP-IN 3260



Swirl-Way® Bathtub

## SPECIFICATIONS

MODEL #	DESCRIPTION	CODES/STANDARDS
5552	60' x 32' x 21-1/4' Bathtub	

MATERIAL	Acrylic, Fiberglass reinforced	WARRANTY	Limited Ten Year
CONSTRUCTION	Bathtub mounted on a pre-leveled base.	SHIPPING WEIGHT	130 lbs.
FLOOR LOADING WEIGHT	47 lbs. / sq. ft.	WATER CAPACITY	52 gal. (max)

## TECHNICAL INFORMATION

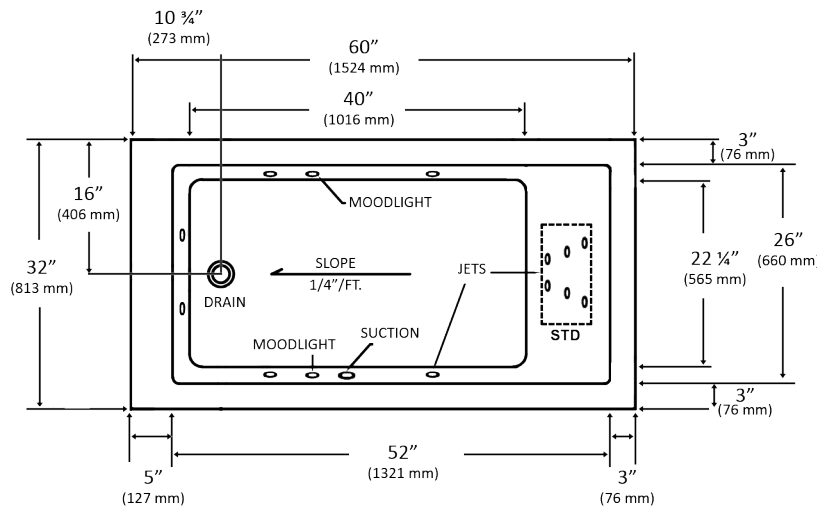

PLUMBING ROUGH-IN

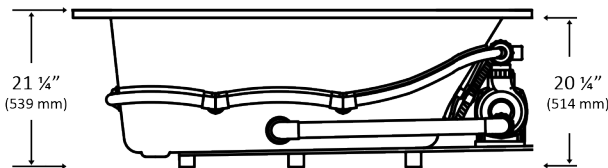
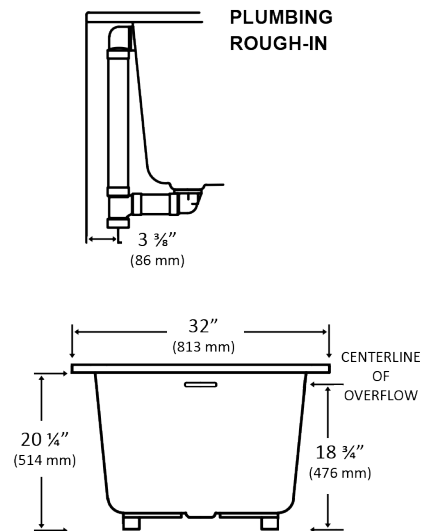

### NOTES:

- 1) Pump location shown for clarity.  
STD. - Standard location only..
- 2) Required pump motor access is 20" W x 15" High
- 3) Measurements may vary 1/4" (+/-)
- 4) If a factory installed nailing flange is added to a unit add 1/8" to each side flanged.
- 5) Removable apron is not available for this unit.
- 6) These dimensions are nominal and subject to change without notice.