

# 2916CTK DENALI® 1.28





Elongated Front, SmartHeight™ Vitreous China, Two-Piece Toilet Kit





## FEATURES

- Complete toilet kit (CTK)
- High performance MagnaFlush™ flushing technology
- 1.28 gpf / 4.8 lpf high efficiency water consumption
- Elongated front, SmartHeight™ bowl
- Pilot anti-siphon fill valve
- 3" rigid flapper flush valve
- 12" rough-in
- SmartFaster™ 2-bolt tank-to-bowl connection
- Model 77 decorative metal trip lever
- 2" glazed trapway
- The Mansfield® limited lifetime warranty on china, Five-year limited warranty on tank trim
- Available in White



|                      |   |   |   |
|----------------------|---|---|---|
| <b>MODEL 2916CTK</b> |  |  |  |
| Toilet seat included | ELONGATED   | SMARTHEIGHT ADA   | CTK   |
| Complete toilet kit  |   |   |   |

## COMPONENTS

| MODEL # | DESCRIPTION   | CODES/STANDARDS   |
|---------|---|---|
| 2916CTK | Elongated front, SmartHeight™ complete toilet kit. Includes: slow close toilet seat, wax toilet ring, floor bolts, caps, and multi-lingual installation instructions. Water supply hardware not included. |     |
| 4977    | Elongated front, SmartHeight™ toilet bowl only. Less toilet seat and supply.  |   |
| 2916    | Tank and cover only, with left hand, side-mount, chrome-plated, metal trip lever. Less supply.  |   |
| 3800    | Elongated, slow close toilet seat   |   |





| TANK TRIM & REPLACEMENT PARTS |   |
|-------------------------------|---|
| 77                            | Trip lever - left hand, side-mount, chrome-plated, metal trip lever |
| 2206                          | Pilot operated fill valve   |
| 2916-1112                     | Denali® 1.28 rigid flapper flush valve                              |
| 630-0030                      | Replacement flush valve seal  |
| 3916-LID                      | Tank lid  |

# 2916CTK DENALI® 1.28



Elongated Front, SmartHeight™ Vitreous China, Two-Piece Toilet Kit

## SPECIFICATIONS

| MODEL # | DESCRIPTION   | CODES/STANDARDS   |
|---------|---|---|
| 2916CTK | Elongated front, SmartHeight™ (1.28 gpf / 4.8 lpf) two-piece toilet kit |     |

|                      |                                 |
|----------------------|---------------------------------|
| MATERIAL             | Vitreous China                  |
| WATER PRESSURE RANGE | 20 to 80 PSI                    |
| FLUSH SYSTEM         | MagnaFlush™ Flushing Technology |
| WATER USAGE          | 1.28 gpf / 4.8 lpf              |
| WATER SURFACE AREA   | 6-1/2" X 9-3/4"                 |
| ROUGH-IN             | 12"                             |
| MaP RATING           | 1,000 grams                     |

|                 |  |
|-----------------|--|
| TRAP DIAMETER   | 2"   |
| TRAP SEAL       | 2"   |
| SHIPPING WEIGHT | Model 2916CTK- 94 lbs. (43 kg)                                     |
| WARRANTY        | Vitreous China - Limited Lifetime<br>Tank Trim - Limited Five-Year |

## TECHNICAL INFORMATION

**Note:** these dimensions are nominal and subject to change without notice.

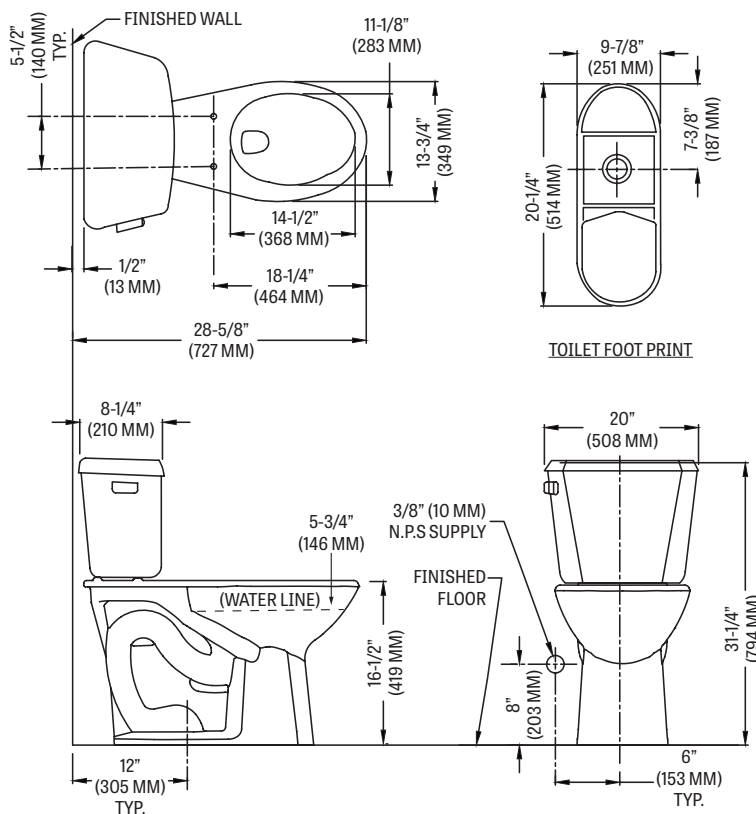

Fixture performance and specifications meet or exceed ASME A112.19.2/CSA B45.1 standards, and other state and local codes.