

5024L/5024R

Barrett™ 60" x 32" x 21 1/2"

Swirl-way® Whirlpool and Bathtub

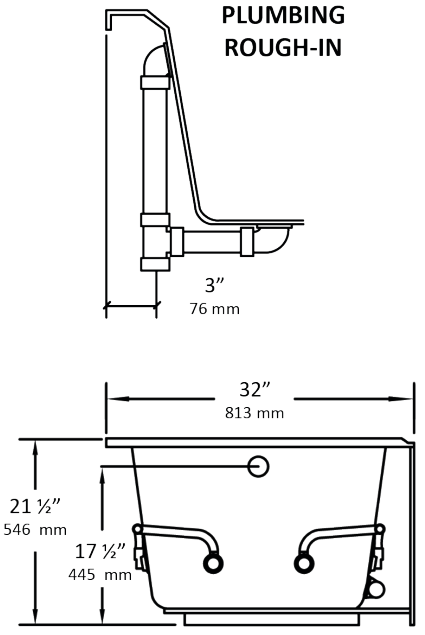
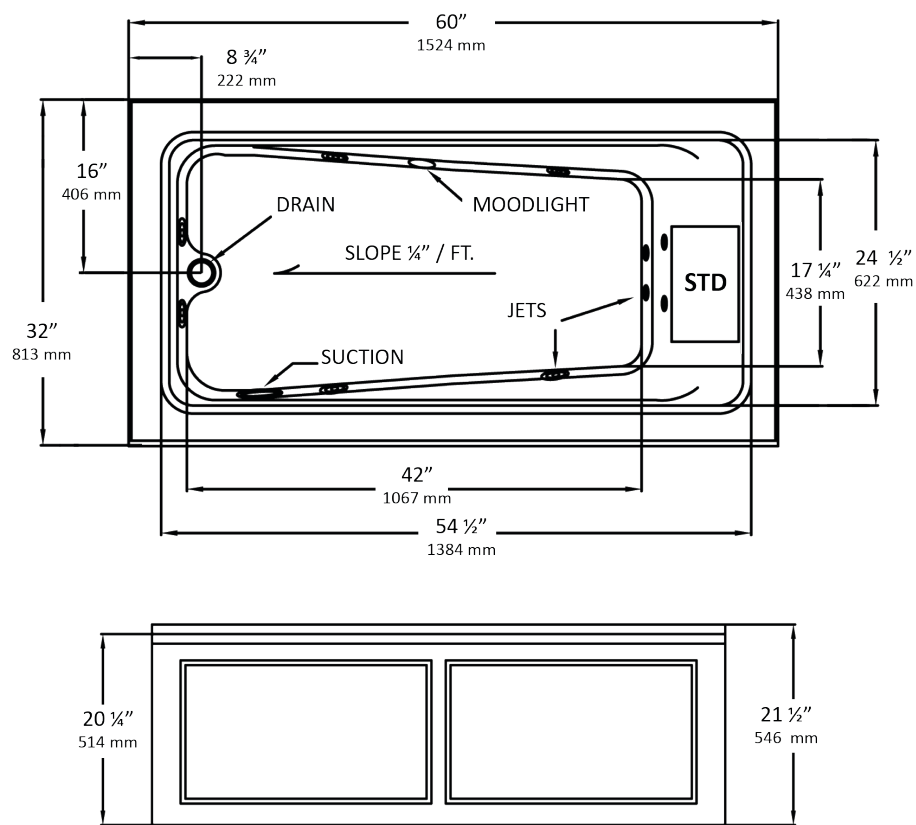

- NOTES:**
1. Pump location shown for clarity.
 2. Required pump motor access is 20" W x 15" H.
 3. Measurements may vary 1/4" (+/-)
 4. Apron is integral with removable access panels for easy access to pump.
 5. These dimensions are nominal and subject to

SPECIFICATIONS

Specification	Description	Specification	Description
Material	Acrylic, fiberglass reinforced	Warranty	Limited Ten Year
Construction	Self-contained, pre-plumbed whirlpool bath system mounted on a pre-leveled base	Water Capacity	27 gal. (min) 57 gal. (max)
Number of Jets	10	Shipping Weight	Whirlpool - 160 lbs
Floor Loading Weight	47 lbs. / sq.ft.		Bathtub - 125 lbs
ESSENTIALS PACKAGE		COMFORT PACKAGE	
Pump Motor	Single speed induction pump, 9 AMP	Pump Motor	Variable speed induction pump, 9 AMP
On/Off Control	One button on/off electronic keypad	On/Off Control	Multi-function electronic keypad
Electrical Requirements	One 120V, 20 amp GFCI dedicated circuit. Optional heater: separate 120 V, 20 amp dedicated circuit.	Electrical Requirements	Two separate 120 V, 20 amp dedicated circuits

