

135-175 ALTO®



Elongated Front, Vitreous China, Two-Piece Toilet

FEATURES

- 3-bolt SmartFasten™ tank-to-bowl connection
- 1.6 gpf / 6.0 lpf low water consumption
- Elongated front bowl
- 2" flush tower
- Fluidmaster® anti-siphon pilot fill valve
- 12" rough-in
- Cover lock tank lid
- Lined tank for reduced condensation
- Model 40 chrome-plated plastic trip lever
- 2" glazed trapway
- The Mansfield® limited lifetime warranty
- Available in White



MODEL 135-175

Toilet seat not included



ELONGATED

COMPONENTS

MODEL #	DESCRIPTION	CODES/STANDARDS
135-175	Elongated front, two-piece toilet.	
135	Elongated front, toilet bowl only. Less toilet seat. Specify color.	
175	Tank and cover only with left hand, front-mount, chrome-plated, plastic trip lever. Fluidmaster® anti-siphon pilot fill valve. Tank liner and cover lock. Less supply.	
TANK TRIM & REPLACEMENT PARTS		
40	Trip lever - chrome-plated, plastic trip lever, left hand	
211-1112	Flush tower	
400A	Fluidmaster® anti-siphon pilot fill valve	
630-0030	Replacement flush valve seal	
165-LID	Tank lid (cover lock)	
Part # 001238891	Locking hardware for cover lock tanks	

135-175 ALTO®



Elongated Front, Vitreous China, Two-Piece Toilet

SPECIFICATIONS

MODEL #	DESCRIPTION	CODES/STANDARDS
135-175	Elongated front (1.6 gpf / 6.0 lpf) two-piece toilet	

MATERIAL	Vitreous China
WATER PRESSURE RANGE	20 to 80 PSI
FLUSH SYSTEM	2" Flush Tower
WATER USAGE	1.6 gpf / 6.0 lpf
WATER SURFACE AREA	9" X 10"
ROUGH-IN	12"
MaP RATING	800 grams

TRAP DIAMETER	2"
TRAP SEAL	2-1/2"
SHIPPING WEIGHT	Model 135 - 50 lbs. (22.6 kg) Model 175 - 34 lbs. (15.4 kg)
WARRANTY	Vitreous China - Limited Lifetime Tank Trim - Limited One Year

TANK OPTIONS

160	Standard 1.6 gpf configuration: 2" flush tower, Fluidmaster® anti-siphon pilot fill valve, left hand, chrome trip lever.
160RH	Variation of model 160, with right hand trip lever.
165	Variation of model 160, with cover lock.
170	Variation of model 160, with tank liner.
172	Variation of model 160, with 2" flapper flush valve and chrome trip lever.
173	Variation of model 160, with 2" flapper flush valve and color-match trip lever.
173RH	Variation of model 173, with right hand trip lever.
174	Variation of model 173, with tank liner.
175	Variation of model 160, with cover lock and tank liner.
180	Variation of model 160, with color-match trip lever.
190	Variation of model 160, with color-match trip lever and tank liner.
125	Variation of model 160, with 14" rough-in.

TECHNICAL INFORMATION

Note: these dimensions are nominal and subject to change without notice.

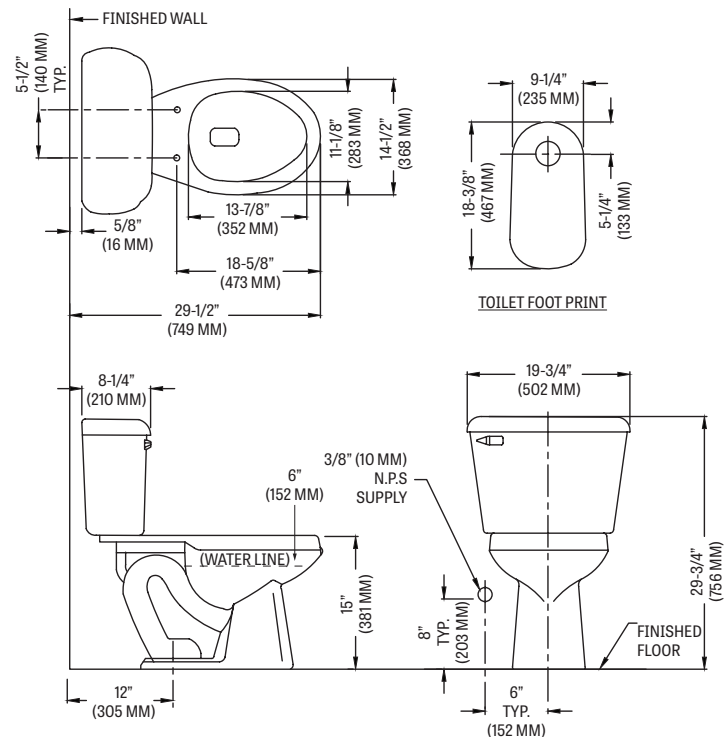

Fixture performance and specifications meet or exceed ASME A112.19.2/CSA B45.1 standards, and other state and local codes.