

5081/5581

Avalon™ 71 3/4" x 40 1/2" x 29"

Swirl-way® Whirlpool and Bathtub

**MANSFIELD®**

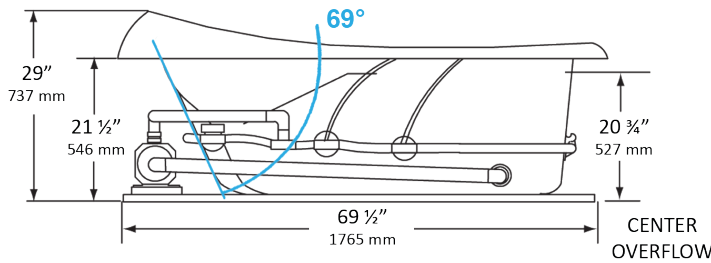
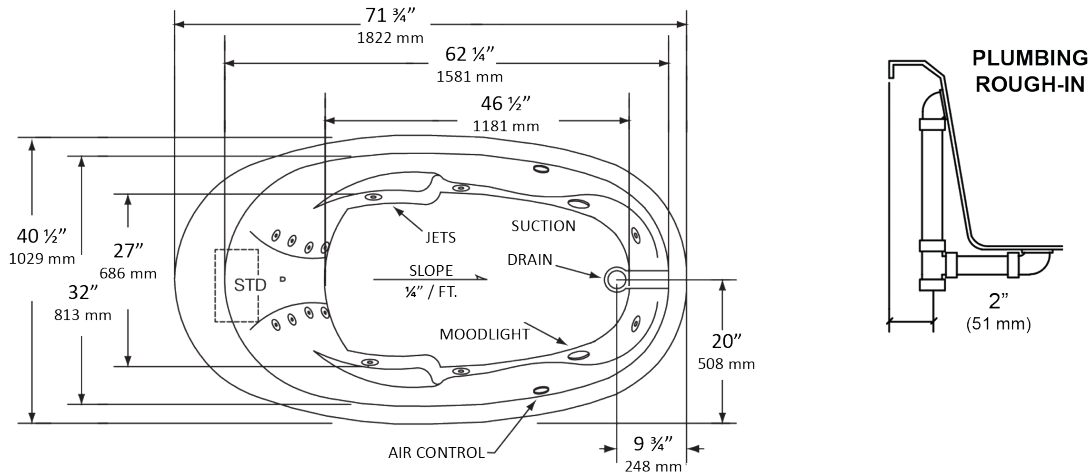

**NOTES:**

1. Pump location shown for clarity.
2. Required pump motor access is 20" W x 15" H.
3. Measurements may vary 1/4" (+/-).
4. Optional removable apron is not available on this unit.
5. Installer note: due to the freeform shape of the tub shell, it is recommended that the tub be on the job before making the final cut-out for drop-in installation.

**SPECIFICATIONS**

Specification	Description	Specification	Description
Material	Acrylic, fiberglass reinforced	Warranty	Limited Ten Year
Construction	Self-contained, pre-plumbed whirlpool bath system mounted on a pre-leveled base	Water Capacity	75 gal. (min) 90 gal. (max)
Number of Jets	14	Shipping Weight	Whirlpool - 152 lbs
Floor Loading Weight	47 lbs. / sq.ft.		Bathtub - 110 lbs
<b>ESSENTIALS PACKAGE</b>		<b>COMFORT PACKAGE</b>	
Pump Motor	Single speed induction pump, 9 AMP	Pump Motor	Variable speed induction pump, 9 AMP
On/Off Control	One button on/off electronic keypad	On/Off Control	Multi-function electronic keypad
Electrical Requirements	One 120V, 20 amp GFCI dedicated circuit. Optional heater: separate 120 V, 20 amp dedicated circuit.	Electrical Requirements	Two separate 120 V, 20 amp dedicated circuits

