

137-160 ALTO®



Elongated Front, SmartHeight™ Vitreous China, Two-Piece Toilet

FEATURES

- 3-bolt SmartFasten™ tank-to-bowl connection
- 1.6 gpf / 6.0 lpf low water consumption
- Elongated front SmartHeight™ bowl
- 2" flush tower
- Fluidmaster® anti-siphon pilot fill valve
- 12" rough-in
- Model 40 chrome-plated plastic trip lever
- 2" glazed trapway
- The Mansfield® limited lifetime warranty
- Available in White, Biscuit, and Bone



MODEL 137-160

Toilet seat not included

Available as CTK



ELONGATED





SMARTHEIGHT ADA



CTK

COMPONENTS



MODEL #	DESCRIPTION	CODES/STANDARDS
137-160	Elongated front, SmartHeight™ two-piece toilet.	 
137	Elongated front, SmartHeight™ toilet bowl only. Less toilet seat. Specify color.	
160	Tank and cover only, with left hand, front-mount, chrome-plated, plastic trip lever. Fluidmaster® anti-siphon pilot fill valve. Less supply. Specify color.	
TANK TRIM & REPLACEMENT PARTS		
40	Trip lever - chrome-plated, plastic trip lever, left hand	
211-1112	Flush tower	
400A	Fluidmaster® anti-siphon pilot fill valve	
630-0030	Replacement flush valve seal	
160-LID	Tank lid	

137-160 ALTO®



Elongated Front, SmartHeight™ Vitreous China, Two-Piece Toilet

SPECIFICATIONS

MODEL #	DESCRIPTION	CODES/STANDARDS
137-160	Elongated front, SmartHeight™ (1.6 gpf / 6.0 lpf) two-piece toilet	 

MATERIAL	Vitreous China
WATER PRESSURE RANGE	20 to 80 PSI
FLUSH SYSTEM	2" Flush Tower
WATER USAGE	1.6 gpf / 6.0 lpf
WATER SURFACE AREA	9" X 10"
ROUGH-IN	12"
MaP RATING	800 grams

TRAP DIAMETER	2"
TRAP SEAL	2-5/8"
SHIPPING WEIGHT	Model 137 - 56 lbs. (25.4 kg) Model 160 - 34 lbs. (15.4 kg)
WARRANTY	Vitreous China - Limited Lifetime Tank Trim - Limited One Year

TANK OPTIONS

160	Standard 1.6 gpf configuration: 2" flush tower, Fluidmaster® anti-siphon pilot fill valve, left hand, chrome trip lever.
160RH	Variation of model 160, with right hand trip lever.
165	Variation of model 160, with cover lock.
170	Variation of model 160, with tank liner.
172	Variation of model 160, with 2" flapper flush valve and chrome trip lever.
173	Variation of model 160, with 2" flapper flush valve and color-match trip lever.
173RH	Variation of model 173, with right hand trip lever.
174	Variation of model 173, with tank liner.
175	Variation of model 160, with cover lock and tank liner.
180	Variation of model 160, with color-match trip lever.
190	Variation of model 160, with color-match trip lever and tank liner.
125	Variation of model 160, with 14" rough-in.

TECHNICAL INFORMATION

Note: these dimensions are nominal and subject to change without notice.

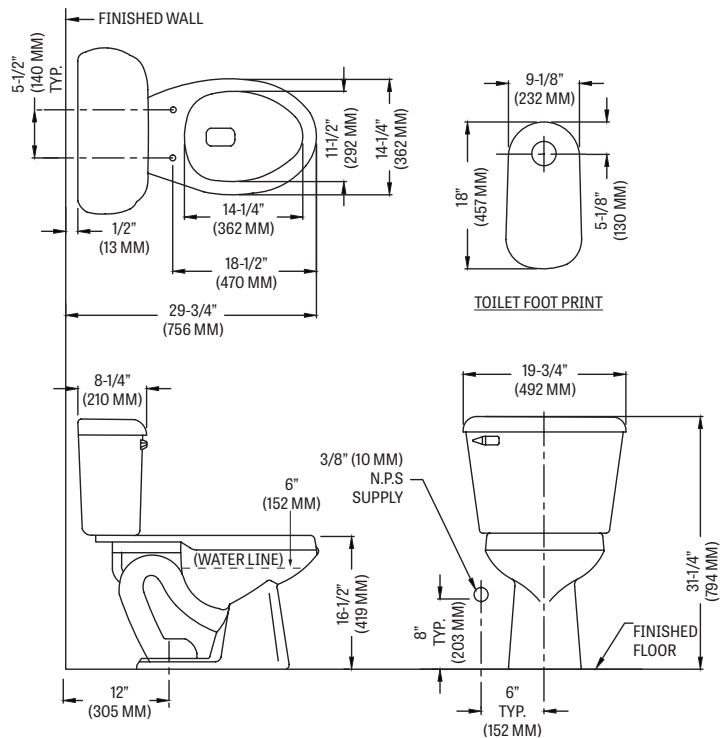

Fixture performance and specifications meet or exceed ASME A112.19.2/CSA B45.1 standards, and other state and local codes.