

Available at

2412593
ITEM NOS. 3637700 / MODEL NO. 5916CTK

MANSFIELD®



DENALI®

Elongated Front, SmartHeight™, Vitreous China, Two-Piece Toilet, Complete Toilet Kit

FEATURES

- Complete toilet kit (CTK)
- 1.28 gpf / 4.8 lpf high efficiency water consumption
- MagnaFlush™ high performance flushing technology
- Elongated front, SmartHeight™ bowl
- 3" Rigid Flapper flush valve – requires less force to flush, is more consistent and uses a simple universal repair part/seal
- Fluidmaster® pilot operated anti-siphon fill valve
- 12" rough-in
- SmartFasten™ 2-bolt tank-to-bowl connection
- Model 77 decorative metal trip lever
- 2" glazed trapway
- The Mansfield® limited lifetime warranty on china, Five-year limited warranty on tank trim
- Available in White and Bone



MODEL 5916CTK

Toilet seat included

Complete Toilet Kit



CTK



ELONGATED



SMARTHEIGHT ADA

COMPONENTS

MODEL #	DESCRIPTION	CODES/STANDARDS
5916CTK	Elongated front, SmartHeight™ complete two-piece toilet kit. Includes: slow close toilet seat, tank and bowl, floor bolts, wax ring, caps and multi-lingual installation instructions. Water supply not included.	
4977	Elongated front, SmartHeight™ toilet bowl only.	
2916	Tank and lid only. With left hand, chrome-plated metal trip lever.	
3800	Elongated, slow close toilet seat	
TANK TRIM & REPLACEMENT PARTS		
77	Trip Lever - chrome-plated metal trip lever, left hand	
400A	Fluidmaster® anti-siphon pilot fill valve	
2206	Anti-siphon pilot fill valve (compatible replacement)	
2916-1112	Denali® 1.28 Rigid Flapper flush valve	
630-0030	Replacement flush valve seal	
3916-LID	Tank lid	

When properly installed, this product meets the requirements for the Americans with Disabilities Act of 1990 (ADA). Refer to local plumbing codes, as they may vary by location and application.

Available at

2412593
ITEM NOS. 3637700 / MODEL NO. 5916CTK

DENALI®

MANSFIELD®



Elongated Front, SmartHeight™, Vitreous China, Two-Piece Toilet, Complete Toilet Kit

SPECIFICATIONS

MODEL #	DESCRIPTION	CODES/STANDARDS
5916CTK	Elongated front, SmartHeight™ (1.28 gpf/4.8 lpf) two-piece toilet kit	HIGH EFFICIENCY TOILET UPC WaterSense ADA COMPLIANT
MATERIAL	Vitreous China	TRAP DIAMETER 2"
WATER PRESSURE RANGE	20 to 80 PSI	TRAP SEAL 2"
FLUSH SYSTEM	3" MagnaFlush™ Flushing Technology	SHIPPING WEIGHT
WATER USAGE	1.28 gpf / 4.8 lpf	Model 5916CTK - 94 lbs. (43 kg)
WATER SURFACE AREA	6-1/2" X 9-3/4"	WARRANTY
ROUGH-IN	12"	Vitreous China - Limited Lifetime Tank Trim - Limited Five-Year
MaP RATING	1,000 grams	

TECHNICAL INFORMATION

Note: these dimensions are nominal and subject to change without notice.

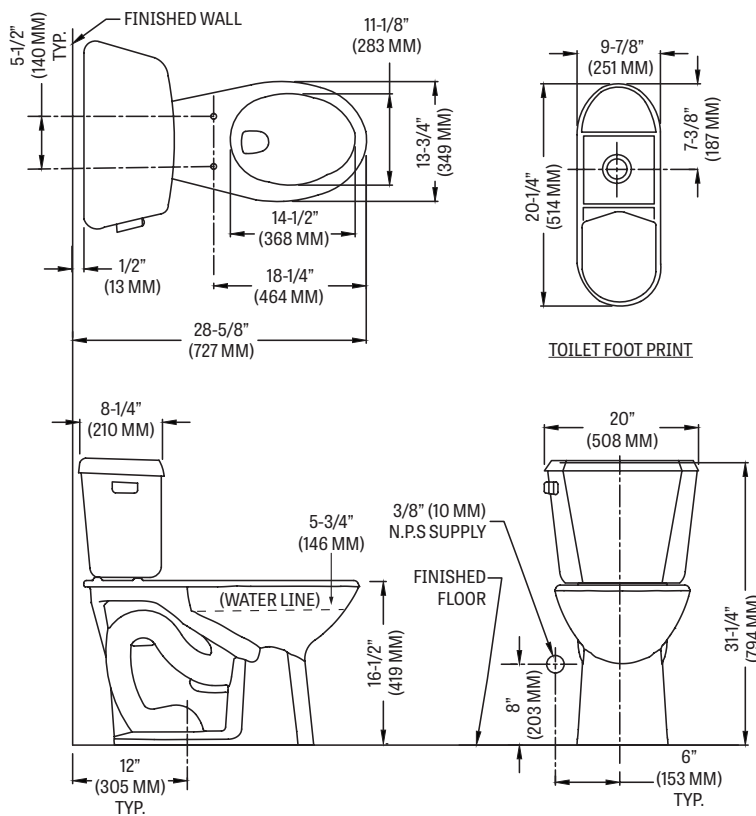

Fixture performance and specifications meet or exceed ASME A112.19.2/CSA B45.1 standards, and other state and local codes.