

# 137-160RH ALTO<sup>®</sup>



Elongated Front, SmartHeight™ Vitreous China, Two-Piece Toilet

## FEATURES

- 3-bolt SmartFasten™ tank-to-bowl connection
- 1.6 gpf / 6.0 lpf low water consumption
- Elongated front SmartHeight™ bowl
- 2" flush tower
- Fluidmaster® anti-siphon pilot fill valve
- 12" rough-in
- Model 40RH chrome-plated plastic trip lever
- 2" glazed trapway
- The Mansfield® limited lifetime warranty
- Available in White, Biscuit, and Bone



**MODEL 137-160RH**

Toilet seat not included





ELONGATED



SMARTHEIGHT ADA

## COMPONENTS



MODEL #	DESCRIPTION	CODES/STANDARDS
<b>137-160RH</b>	Elongated front, SmartHeight™ two-piece toilet.	 
<b>137</b>	Elongated front, SmartHeight™ toilet bowl only. Less toilet seat. Specify color.	
<b>160RH</b>	Tank and cover only, with right hand, front-mount, chrome-plated, plastic trip lever. Fluidmaster® anti-siphon pilot fill valve. Less supply. Specify color.	
TANK TRIM & REPLACEMENT PARTS		
<b>40RH</b>	Trip lever - chrome-plated, plastic trip lever, right hand	
<b>211-1112</b>	Flush tower	
<b>400A</b>	Fluidmaster® anti-siphon pilot fill valve	
<b>630-0030</b>	Replacement flush valve seal	
<b>160-LID</b>	Tank lid	

# 137-160RH ALTO®



Elongated Front, SmartHeight™ Vitreous China, Two-Piece Toilet

## SPECIFICATIONS

MODEL #	DESCRIPTION	CODES/STANDARDS
137-160RH	Elongated front, SmartHeight™ (1.6 gpf / 6.0 lpf) two-piece toilet	 

MATERIAL	Vitreous China
WATER PRESSURE RANGE	20 to 80 PSI
FLUSH SYSTEM	2" Flush Tower
WATER USAGE	1.6 gpf / 6.0 lpf
WATER SURFACE AREA	9" X 10"
ROUGH-IN	12"
MaP RATING	800 grams

TRAP DIAMETER	2"
TRAP SEAL	2-5/8"
SHIPPING WEIGHT	Model 137 - 56 lbs. (25.4 kg) Model 160RH - 34 lbs. (15.4 kg)
WARRANTY	Vitreous China - Limited Lifetime Tank Trim - Limited One Year

TANK OPTIONS	TECHNICAL INFORMATION
--------------	-----------------------

<b>160</b>	<b>Standard 1.6 gpf configuration:</b> 2" flush tower, Fluidmaster® anti-siphon pilot fill valve, left hand, chrome trip lever.
<b>160RH</b>	Variation of model 160, with right hand trip lever.
<b>165</b>	Variation of model 160, with cover lock.
<b>170</b>	Variation of model 160, with tank liner.
<b>172</b>	Variation of model 160, with 2" flapper flush valve and chrome trip lever.
<b>173</b>	Variation of model 160, with 2" flapper flush valve and color-match trip lever.
<b>173RH</b>	Variation of model 173, with right hand trip lever.
<b>174</b>	Variation of model 173, with tank liner.
<b>175</b>	Variation of model 160, with cover lock and tank liner.
<b>180</b>	Variation of model 160, with color-match trip lever.
<b>190</b>	Variation of model 160, with color-match trip lever and tank liner.
<b>125</b>	Variation of model 160, with 14" rough-in.

Note: these dimensions are nominal and subject to change without notice.

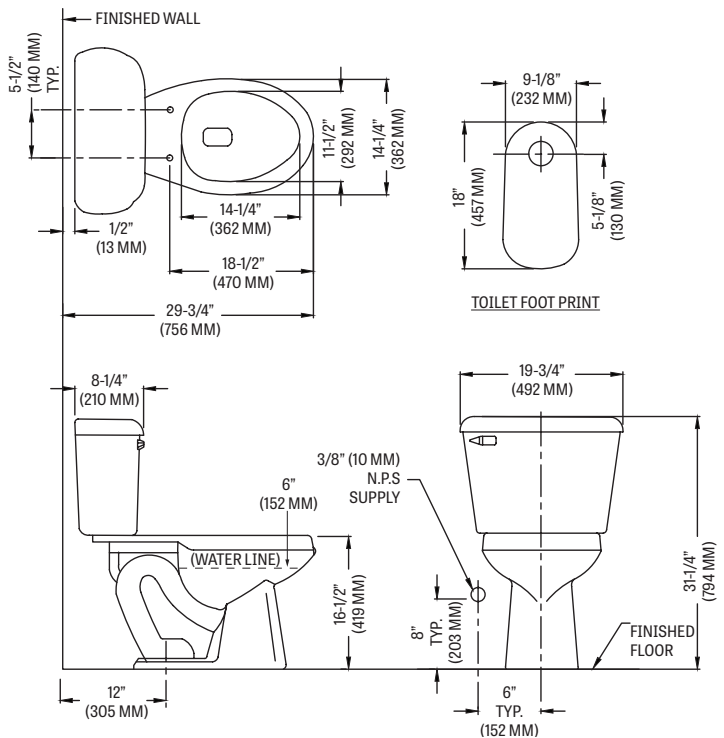

Fixture performance and specifications meet or exceed ASME A112.19.2/CSA B45.1 standards, and other state and local codes.