

# PRO-FIT<sup>®</sup> AIR MASSAGE BATH

3666 TFS 66" x 36" x 21 1/2"

Model number: 6458 LH, 6459 RH

# MANSFIELD<sup>™</sup>

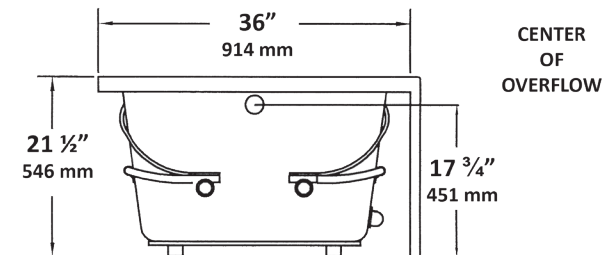
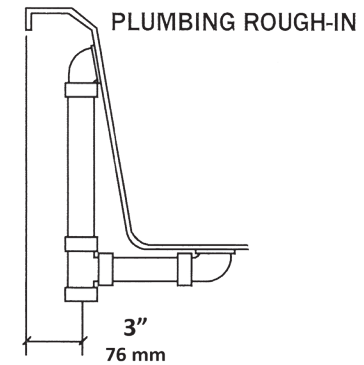
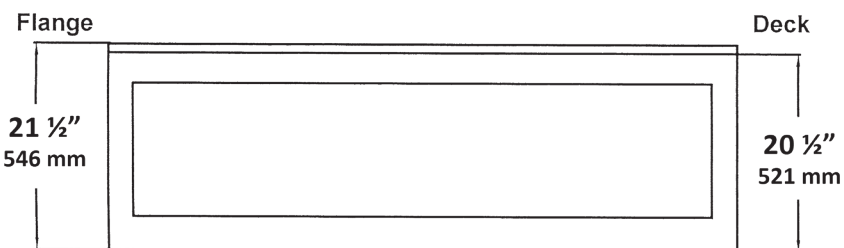
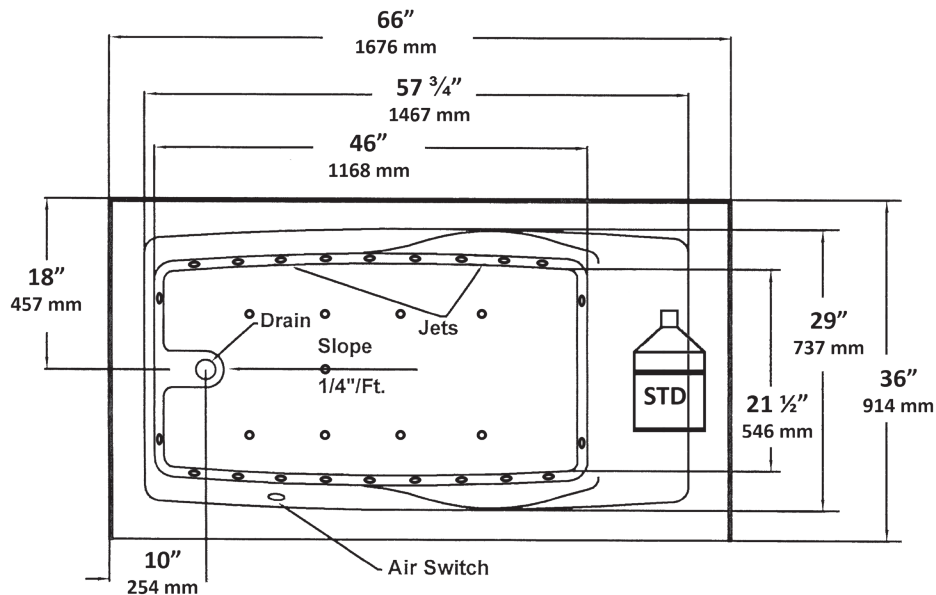

#### Notes:

1. Blower location shown for clarity.
2. Required pump motor access is 20" W x 15" H.
3. Measurements may vary 1/4" (+/-)
4. Apron is integral with optional removable access panel.
5. Removable access panel provides access to blower/motor.
6. Specify LH or RH drain when ordering.

#### SPECIFICATIONS:

<b>Dimensions:</b>	66" x 36" x 21 1/2"	<b>Number of jets:</b>	31
<b>Material:</b>	Acrylic, fiberglass reinforced	<b>Weight:</b>	Air Bath - 90 lbs. (41 kg)
<b>Blower Motor:</b>	120 V, 60 HZ, 8.0 Amp, 200 Watt, Single Speed, Premounted	<b>Water Capacity:</b>	80 gals max., 35 gals min. (303/134 liters)
<b>Electrical Requirements:</b>	120 V, 15 Amp, GFCI Protected	<b>Floor Loading:</b>	47 lbs./sq.ft. (229 kg/m <sup>2</sup> )
<b>On/Off Control:</b>	Air Switch	<b>Shipping Weight:</b>	125 lbs. (57 kg)